

Blade Quick Connect Harness 2019+ Silverado/Sierra LD Trucks

Congratulations on your purchase of a high quality PUTCO product. Should you need any application or technical assistance, feel free to call us at: 1-800-247-3974

Monday-Friday 8:00 a.m. - 5:00 p.m. (Central Standard Time)

KIT CONTENTS:	
Description	Qty
Quick Connect Harness	1

Additional Tools Needed:

- Clean cloth
- At least 90% Isopropyl Alcohol
- Zip-Ties

Installation Instructions — Blade Light Bar Sold Separately!

1. Verify the kit contents above.
2. Clean and dry the vehicle thoroughly in location where light bar is to be installed.
3. Vehicle surface temperature must be a minimum of 15°C (60°F).
4. Remove tail gate to make mounting Blade easier.
5. Install 3M tape on back of black plastic brackets. Use promotor packets to prep surface on bracket where tape is going to be applied. Do not use promotor on painted surfaces.
6. Light bar brackets need to be 1/4" to 5/16" above metal "ridge" to allow enough clearance between tail gate and lightbar
 - Use light bar bracket to achieve proper gap between ridge and light bar (Figure 1).

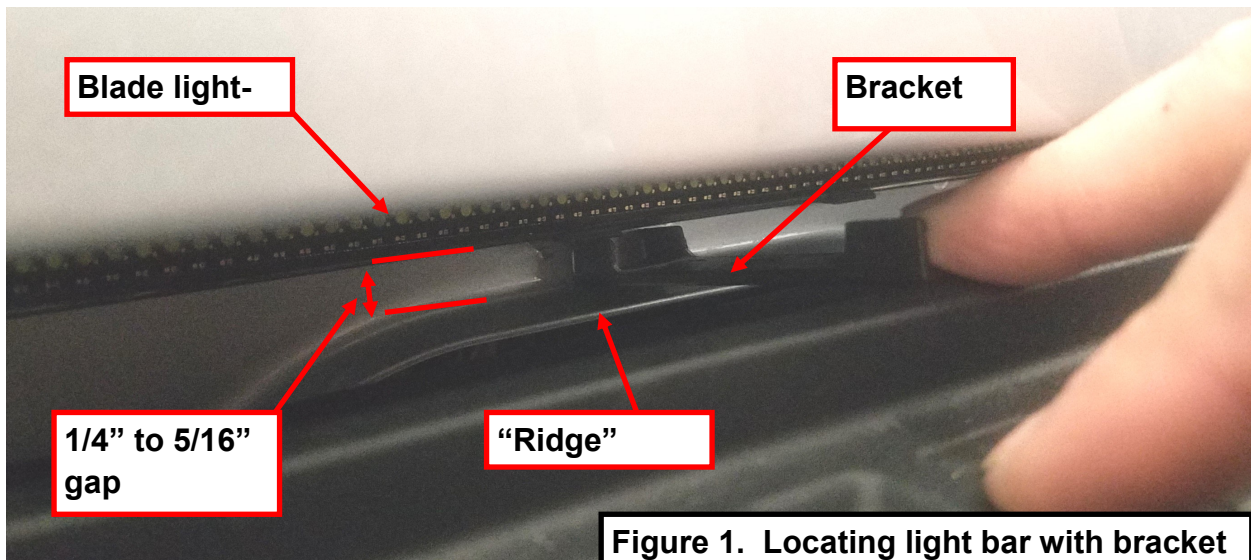
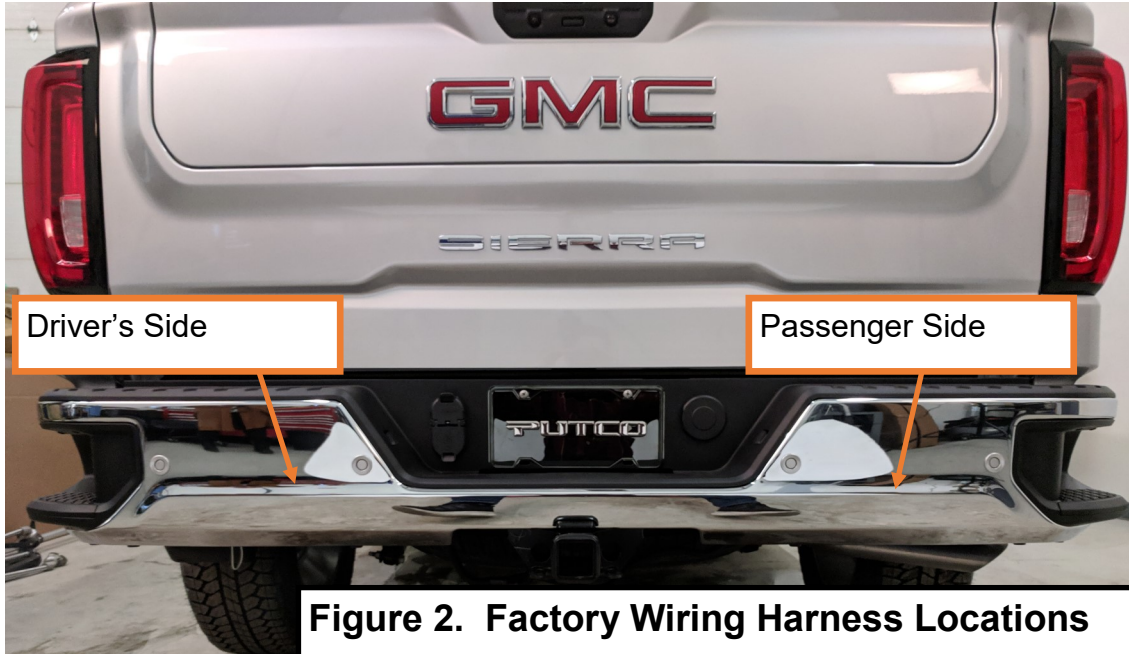

Figure 1. Locating light bar with bracket

7. Remove tape release liner on all brackets. Place light bar in chosen position on the bed of truck, insuring proper gap shown in **Figure 1**. Do not stick tape to truck until light bar is in correct position. Light bar wire should exit toward driver side of truck.

Wiring Installation with Quick Connect Harness (2019+ Silverado/Sierra)



1. Factory wire harness are located behind the rear bumper, near the spare tire, frame rails, and exhaust. Shown in **Figures 2 and 3**.

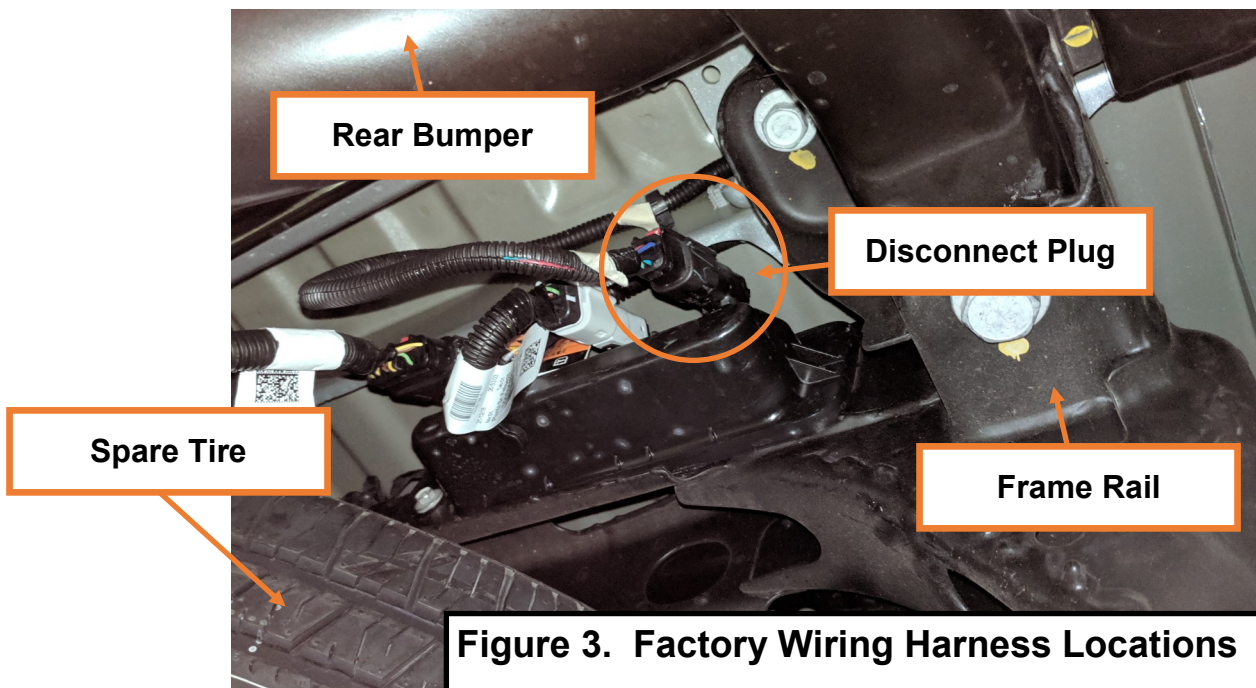

2. Disconnect the black plug shown in **Figure 3** (passenger's side pictured).
3. **IMPORTANT!** Make sure to plug each end of the quick connect harness into the appropriate side of the vehicle, as identified in **Figure 4**.
4. Plug in the Quick Connect Harness into the factory wiring harness (**Figure 5**). Repeat on driver's side.

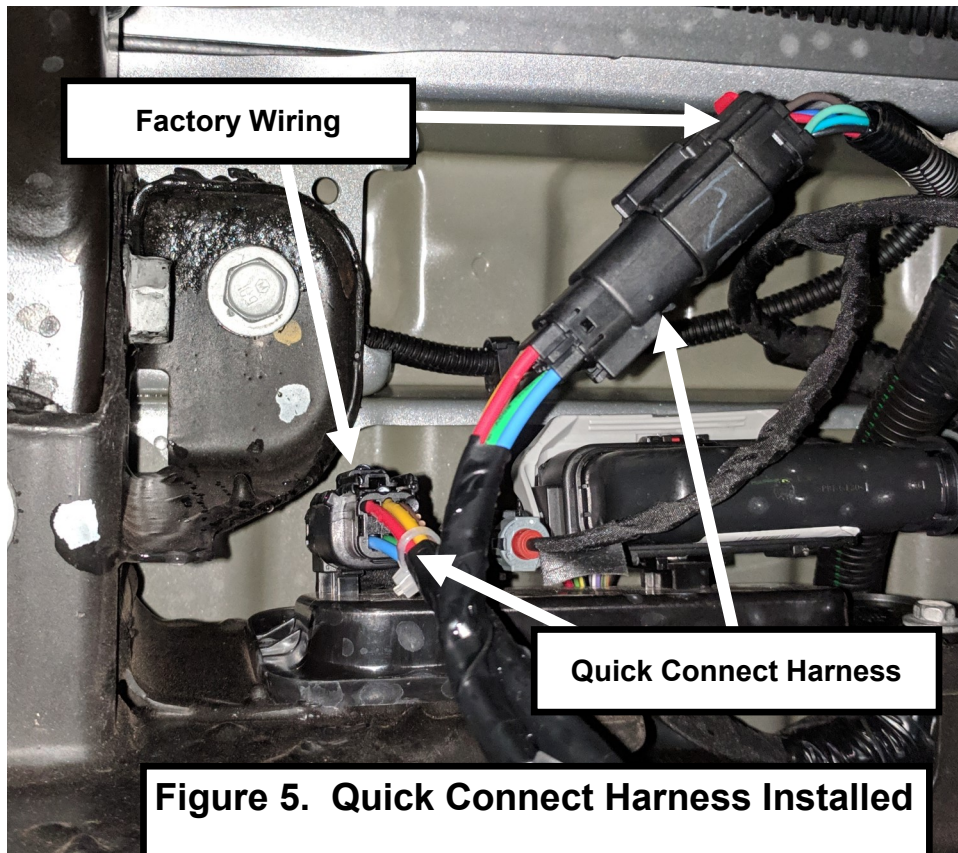
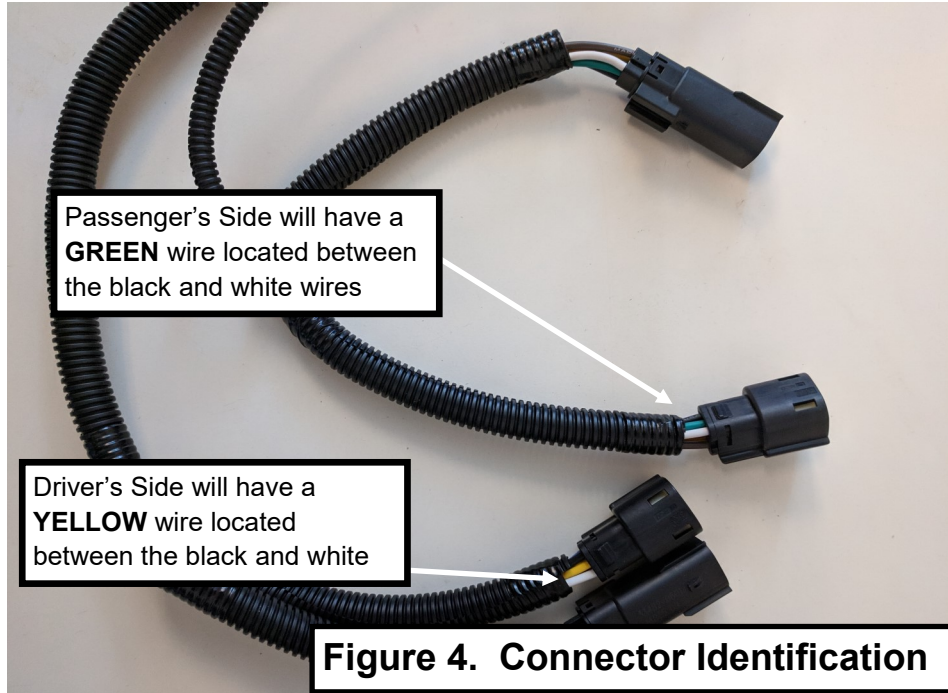

5. Route the Blade Quick Connect Harness along inner bumper and zip-tie safely into place.
6. Connect the 4-pin plug and reverse plug of the Blade Quick Connect Harness to the Blade Lightbar (**Figure 6**).
7. Zip-tie the Blade driver box behind the bumper. Make sure it is safely away from road debris, pinch points, and hot exhaust parts.

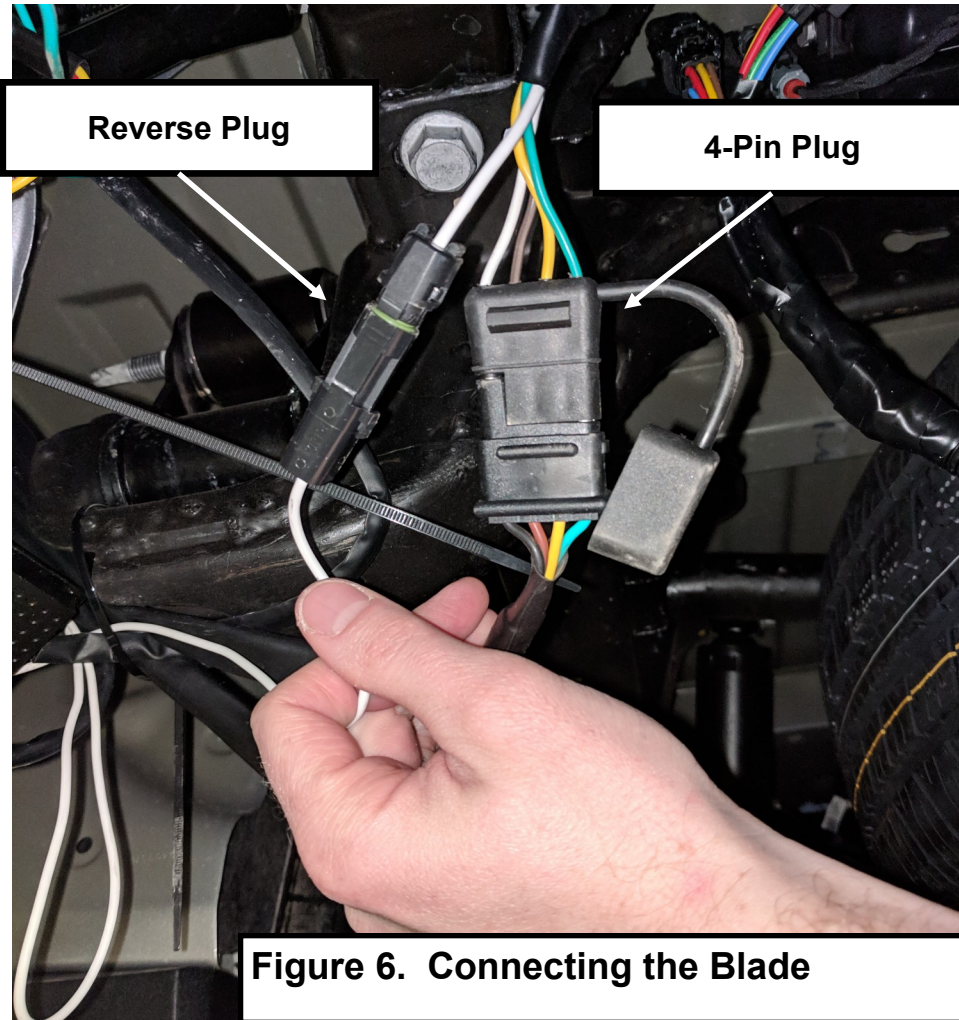

8. With the help of an assistant, test the functionality of the Blade (brake, turn signals, and reverse).

Enjoy Your New Putco Product!