

PUTCO®

MOLLE PANELS

- MODULAR LIGHTWEIGHT LOAD CARRYING EQUIPMENT -

INSTRUCTION GUIDE

RAM 2500/3500

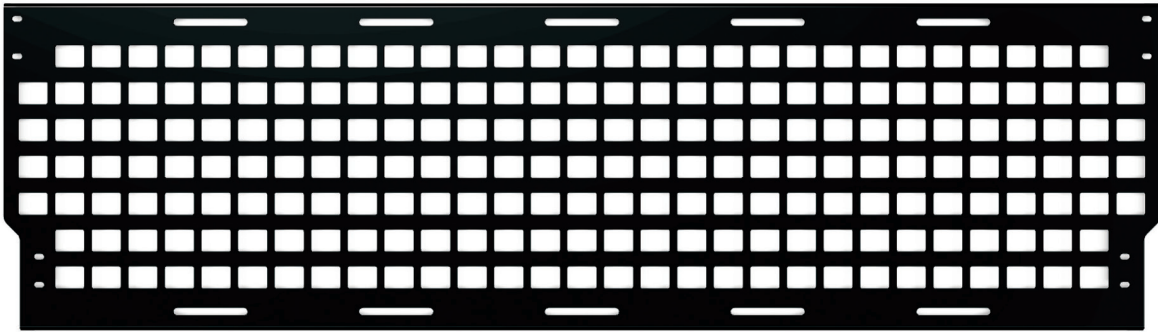

FRONT PANEL

Congratulations on your purchase of a high quality PUTCO® product. Should you need any application or technical assistance, feel free to call us at:

1-800-247-3974

Monday-Friday 8:00am - 5:00pm (Central Standard Time)
Contact your PUTCO® dealer for other quality accessories.



**PLEASE READ ALL INSTRUCTIONS BEFORE INSTALLATION
AND CHECK TO SEE THAT ALL PARTS ARE INCLUDED**

REQUIRED TOOLS

3/16" HEX KEY



7/32" HEX KEY



T30 TORX DRIVER



10MM WRENCH



CONTENT LIST

DESCRIPTION	QTY
Molle Front Plate	1
Front Upper Brackets	2
Front Lower Brackets	2
M6 Torx-Head Bolt	8
Rubber Feet	3
Jam Nuts	3
3/4" Well Nut	2
3/8"-16 X 1.5" Allen Head Bolt	2
5/16"-18 X 2 3/8" Allen Head Bolt	2
In-Bed Washer	2
Nut Plate	2



INSTALLATION INSTRUCTIONS

- 1** Gather the two Front Upper Brackets. Loosely assemble one 2-3/8" long Allen head bolt, In-Bed Washer, and Nut Plate onto each of these brackets.
- 2** Install the Front Upper Bracket assemblies by inserting the Nut Plate into the slot located towards the top of each bed side as shown in the pictures on the next page. The nut plate will have to be inserted at an angle in order to fit. During this process, use caution so you do not loosen the nut plate and drop it behind the slot! Next, orient the nut plate so that it is perpendicular and centered behind the slot, then push the tabbed washer against the bed side so that the tabs fit into the slot. If aligned correctly, the tabs should prevent the nut plate from spinning. While keeping the tabbed washer in the slot, pull back on the bolt and begin to tighten until snug, but do not fully tighten, as the position of the bracket may need to be adjusted. Perform this step for both driver and passenger side.

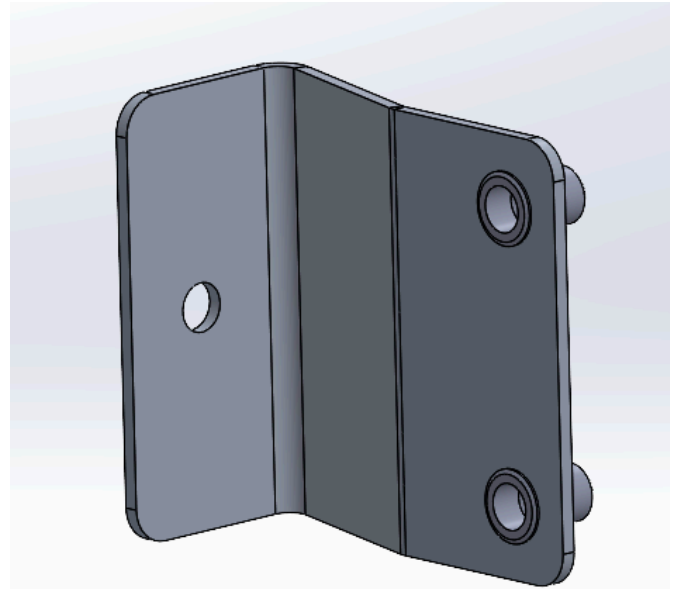

Front Upper Bracket



- 3** Next, locate the two remaining Front Lower Brackets. Loosely assemble a 3/4-inch well nut and 1.5-inch long Allen head bolt onto each bracket. Install the lower bracket assemblies by inserting the well nut into the slot located just next to the forward tie-down hook. Tighten the bolt using a 7/32 hex key until the well nut is snug in the slot, but do not overtighten. Once all brackets are installed, the bed of your Ram should look like the picture on the next page.

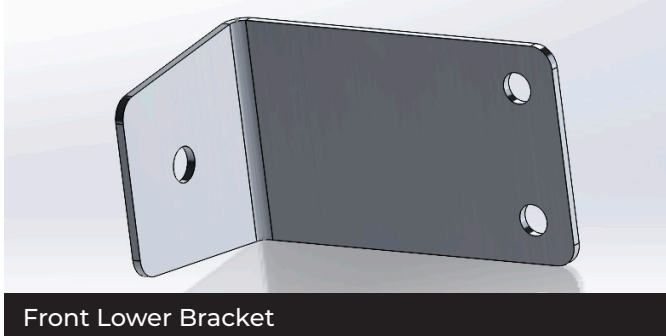

- 4 Next, prepare the Molle Front Plate to be installed. Thread a jam nut onto each of the rubber feet, then loosely screw the rubber feet into the riv nuts located on the bottom flange of the front plate.
- 5 Fasten all three molle plates to their brackets using the provided Torx-head screws and a T30 Torx driver.
- 6 Screw the rubber feet in the front plate down until they are snug against the bed floor, then lock the feet in place by tightening the jam nut against the front plate using a 10mm wrench.
- 7 Now that everything is installed, ensure that all fasteners have been tightened until snug, but do not overtighten.

Your new MOLLE Panels are now successfully installed on your vehicle!



Completed Molle Panel kit for Ram 2500 / 3500